

■比例電磁式リリーフ付減圧弁 Proportional Electro-Hydraulic Relieving and Reducing Valves

小形・高性能のEHシリーズの比例電磁式パイロットリリーフ弁とリリーフ付減圧弁を一体に組合せたもので、油圧システム内の圧力を入力電圧に対して、比例的に制御することができます。

また、リリーフ機構を備えていますので、負荷容量が大きい場合でも降圧時の応答速度は良好です。

These valves consist of a small size but high performance EH series electro-hydraulic proportional pilot relief valve and reducing valve with relief function. The valves control the system pressure proportionally through a controlled input voltage.

Moreover, a good response speed in reducing the pressure even at a large load capacity can be obtained with the relief function of the valves.

■仕様 Specifications

項目 Descriptions	モデル番号 Model Numbers	EHRBG-06	EHRBG-10
最高使用圧力 Max. Operating Pres.		24.5 MPa	
最大流量 Max. Flow		100 L/min	250 L/min
最大リリーフ流量 Max. Relieving Flow		35 L/min ^{★1}	15 L/min ^{★1}
圧力調整範囲 Pressure Adjustment Range		“モデル番号の構成”参照 Refer to Model Number Designation	
コイル抵抗 Coil Resistance		10 Ω	
ヒステリシス Hysteresis		3%以下 3% or less	
繰返し性 Repeatability		1%以下 ^{★2} 1% or less ^{★2}	
周波数特性 Frequency Response		44ページの周波数特性参照 Refer to Frequency Response on Page 44	
供給電源電圧 Supply Electric Power		DC 24V (DC 21V~28V含むリップル) 21V to 28V DC Included Ripple	
最大消費電力 Power Input (Max.)		28W	
入力信号電圧 Input Signal Voltage		B: 6.9 MPa/DC 5V C: 13.7 MPa/DC 5V (通過流量0時) H: 20.6 MPa/DC 5V (at Flow Rate Zero)	
入力インピーダンス Input Impedance		10 kΩ	
圧力信号出力 Pressure Signal Output		B: DC 5V / 6.9 MPa C: DC 5V / 13.7 MPa H: DC 5V / 20.6 MPa	
使用周囲温度 Ambient Temperature		0~50℃ (通風のある場合) with Circulated Air	
質量 Mass		40,41ページ参照 Refer to Page 40 & 41	

★1 2次側圧力ポートとタンクポートの差圧が13.7 MPaの場合の値です。

★2 同一使用条件における弁単体の場合の値です。

★1 The figures shown are those obtained where the differential pressure between the secondary pressure port and tank port is 13.7 MPa.

★2 The repeatability of the valve is obtained by having it tested independently on the conditions similar to its original testing.

■モデル番号の構成 Model Number Designation

EHRB	G	-06	-C	-S	-50
シリーズ番号 Series Number	管接続形式 Type of Mounting	大きさの呼び Valve Size	圧力調整範囲 Pres. Adj. Range MPa	制御方式 Control Type	デザイン番号 Design Number
EHRB : 比例電磁式リリーフ付減圧弁 Proportional Electro-Hydraulic Relieving & Reducing Valve	G : サブプレート 取付形 Sub-Plate Mounting	06	B: 0.8 ~ 6.9 C: 1.2 ~ 13.7 H: 1.5 ~ 20.6	無記号: オープンループ None: Open-Loop	50
		10	B: 0.9 ~ 6.9 C: 1.2 ~ 13.7 H: 1.5 ~ 20.6	S: オープンループ・センサ内蔵 Open-Loop with Sensor	50

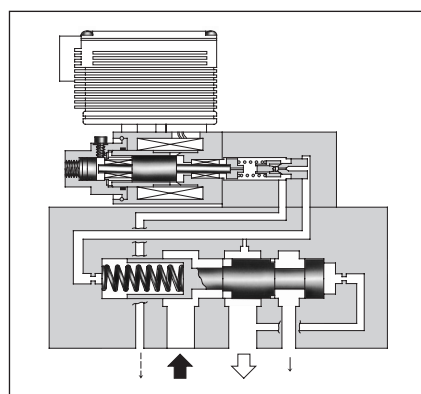
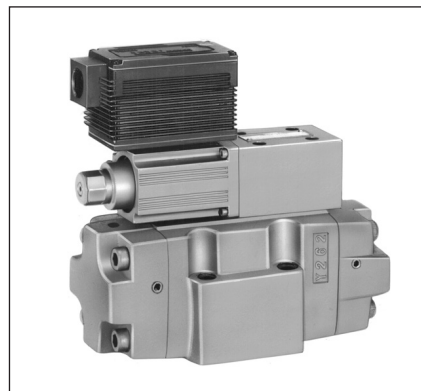

JIS油圧図記号
Graphic Symbols

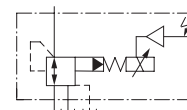

オープンループ形
Open-Loop Type

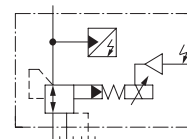

オープンループ・センサ内蔵形
Open-Loop Type with Sensor

■サブプレート Sub-Plate

弁モデル番号 Valve Model No.	サブプレート モデル番号 Sub-Plate Model No.	接続口径 Thread Size Rc	質量 Mass kg
EHRBG-06	ERBGM-06-20	3/4	3.0
EHRBG-10	ERBGM-10-10	1 1/4	6.5

●サブプレートをご使用の場合は、上記モデル番号にてご注文ください。なお、サブプレートをご使用にならない場合は弁取付面を6S程度に仕上げてください。

●Sub-plates are available. Specify sub-plates model from the table above. When sub-plates are not used, the mounting surface should have a good machined finish.

■使用上の注意

●設定圧力に対する必要1次側圧力

1次側圧力は設定圧力に1MPa加算した圧力を必要とします。

●ドレンポート

背圧が0.2MPa以下になるようにして、直接油タンクに接続し、管の端末は必ず油中に入れてください。

●負荷容量

負荷容量は、約20Lでのご使用を推奨いたします。なお、最低でも負荷容量は1.4L以上でのご使用ください。

■付属品 Attachment

●取付ボルト Mounting Bolts

モデル番号 Model No.	六角穴付ボルト Socket Head Cap Screw
EHRBG-06	M10×70 L 4個 4 Pcs.
EHRBG-10	M10×70 L 6個 6 Pcs.

■Instructions

●Pressure at the Primary Pressure Port

The necessary pressure at the primary pressure port should be equal to the set pressure plus 1 MPa.

●Drain Port

The back pressure at the drain port should be less than 0.2 MPa. The pipe from the drain port should be connected to the reservoir directly and the end of the pipe must always be in the oil.

●Load Capacity

The use of the valves at the load capacity of about 20 L is recommended. Even at the lowest, a load capacity of more than 1.4 L is required.

●EHRBG-06-※-50 : オープンループ形 Open-Loop Type

●EHRBG-06-※-S-50 : オープンループ・センサ内蔵形 Open-Loop Type with Sensor

質量 Approx. Mass

オープンループ形 Open-Loop Type12.3 kg

オープンループ・センサ内蔵形13 kg
Open-Loop Type with Sensor

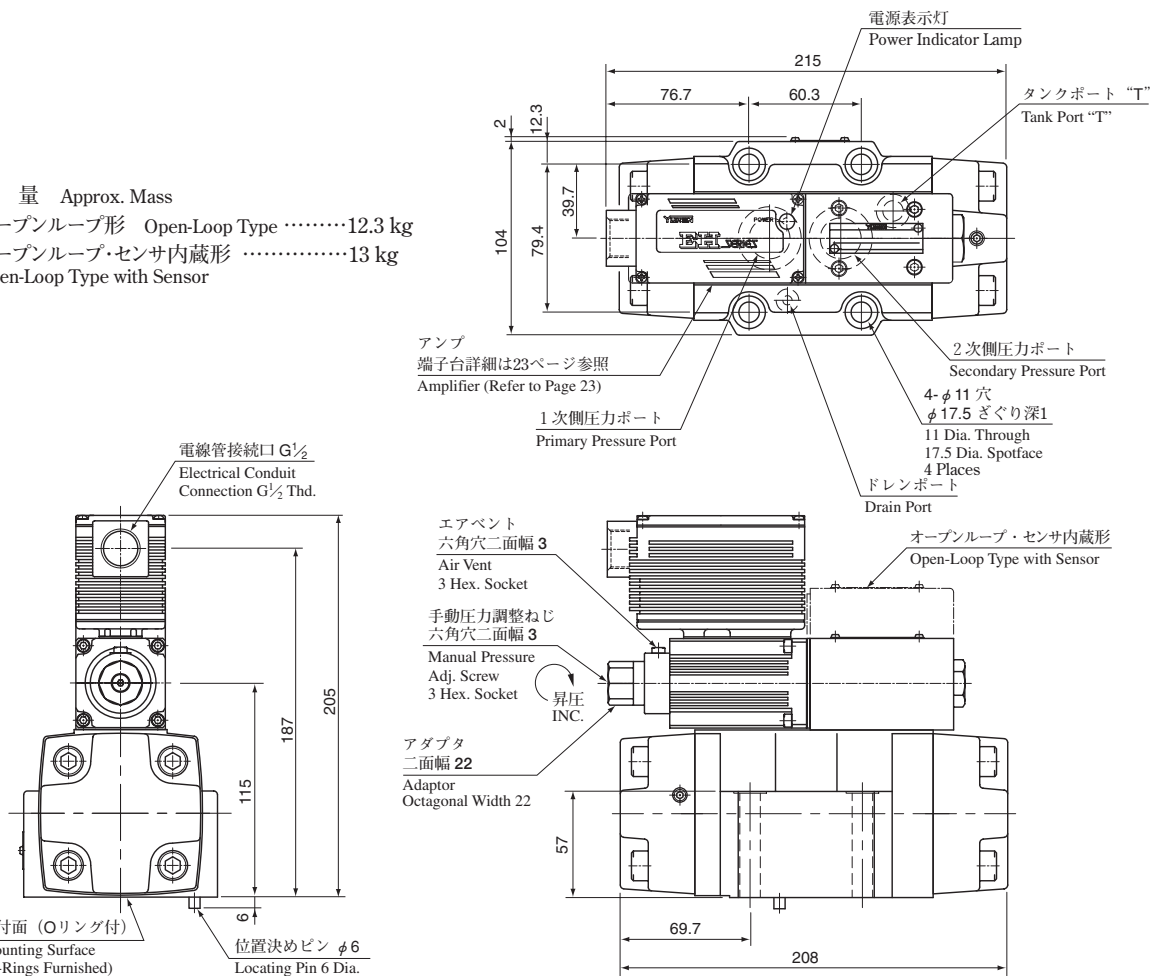

●EHRBG-10-※-50 : オープンループ形 Open-Loop Type

●EHRBG-10-※-S-50 : オープンループ・センサ内蔵形 Open-Loop Type with Sensor

質量 Approx. Mass

オープンループ形 Open-Loop Type13.8 kg

オープンループ・センサ内蔵形14.5 kg
Open-Loop Type with Sensor

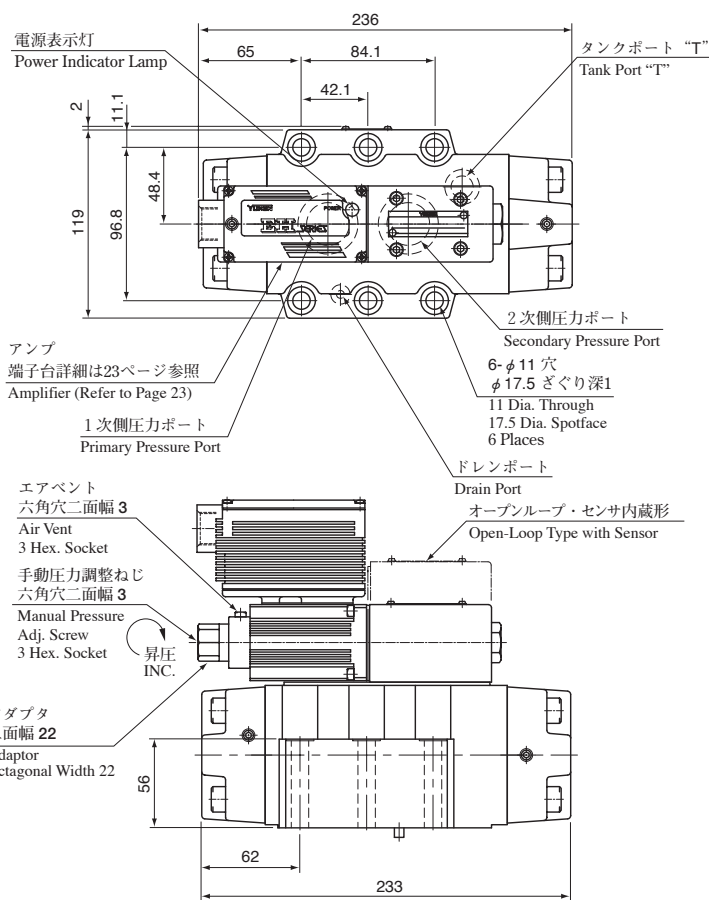
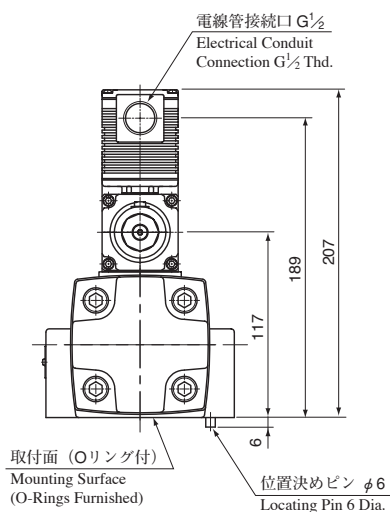

サブプレート Sub-Plate

ERBGM-06

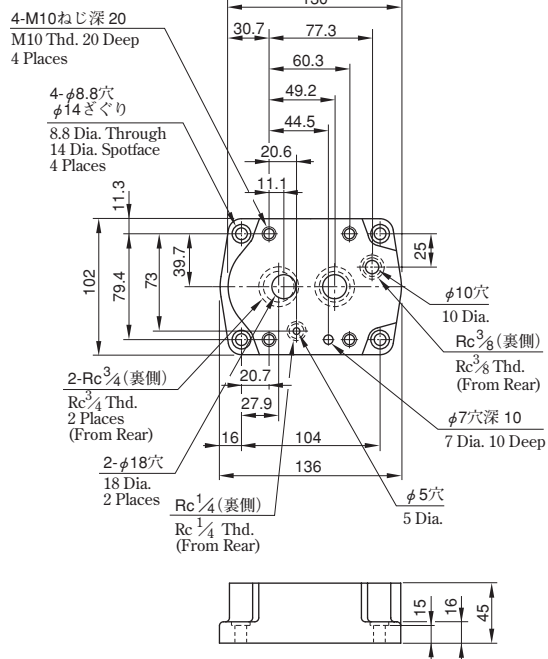

ERBGM-10

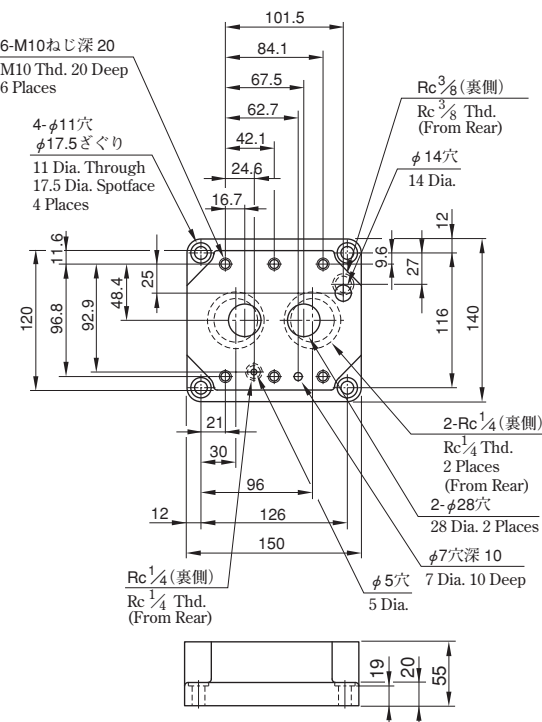

■入力信号電圧-2次側圧力特性 Input Signal Voltage vs. Secondary Pressure

一次側圧力 Primary Pressure : 24.5 MPa
 粘度 Viscosity : 30 mm²/s

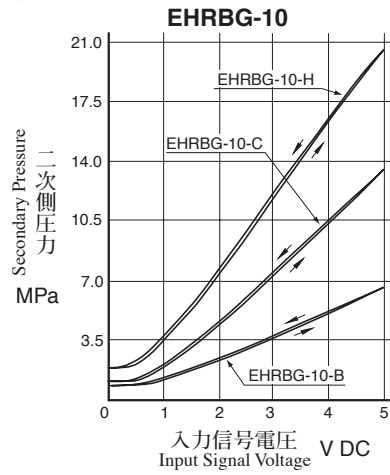
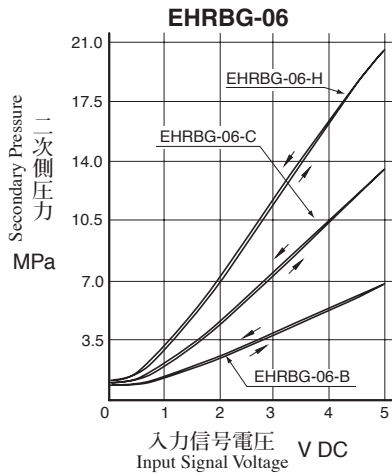

■流量-2次側圧力特性 Flow vs. Secondary Pressure

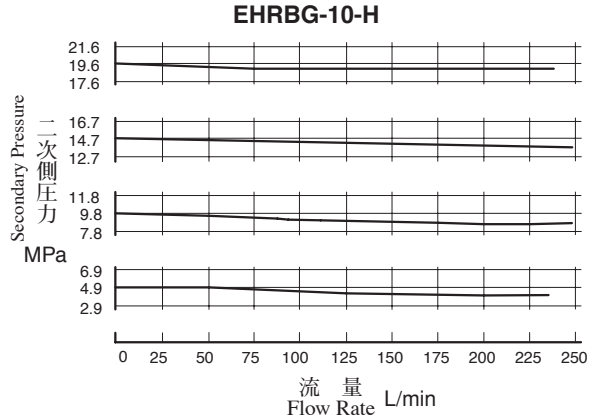
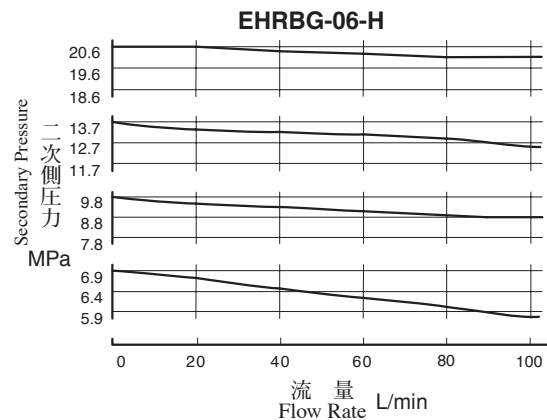
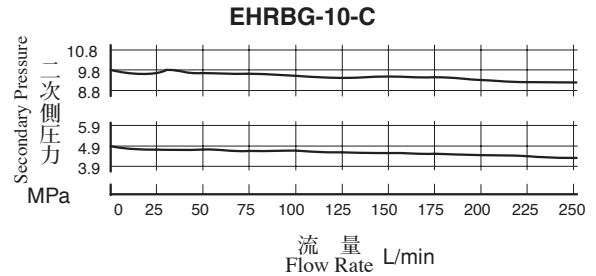
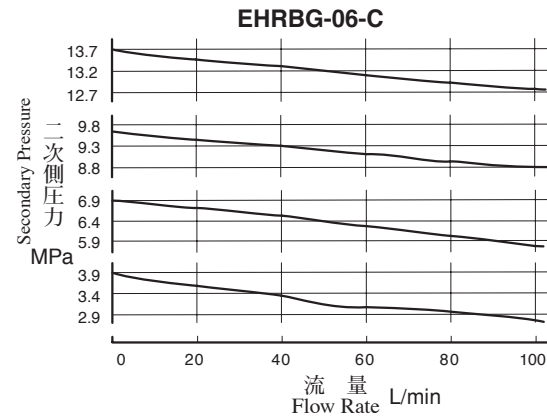
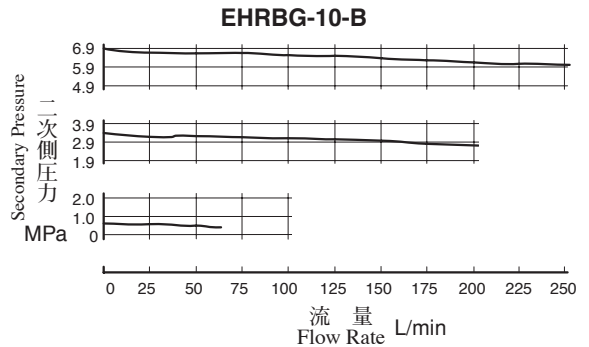
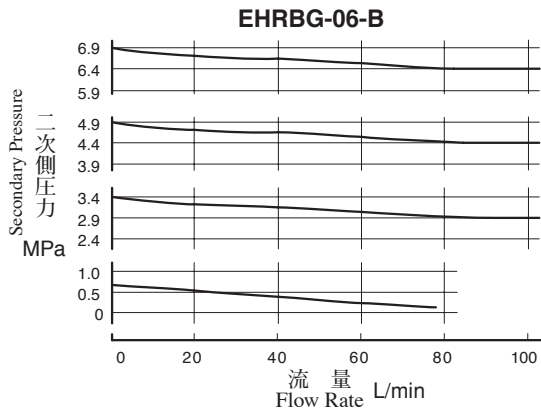

■粘度-二次側圧力特性 Viscosity vs. Secondary Pressure

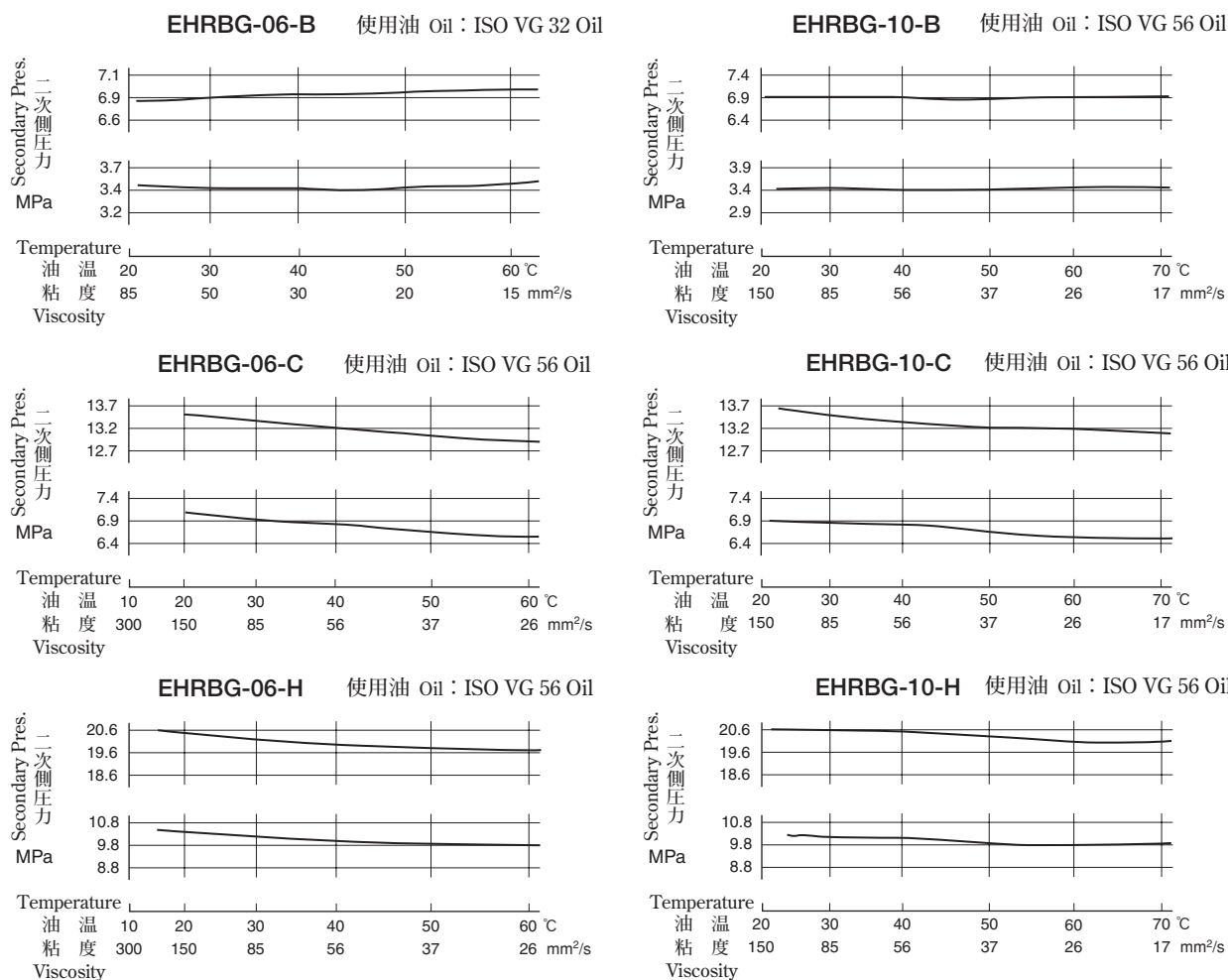

■ステップ応答特性(例) Step Response (Example)

本特性は負荷容量20Lにおけるものです。負荷容量が変わる場合、本特性とは異なります。

The following step response measurements are taken when the trapped oil volume is 20 L. The step response varies by trapped oil volume.

一次側圧力 Primary Pressure : 24.5 MPa
 負荷容量 Trapped Oil Volume : 20 L
 粘度 Viscosity : 30 mm²/s

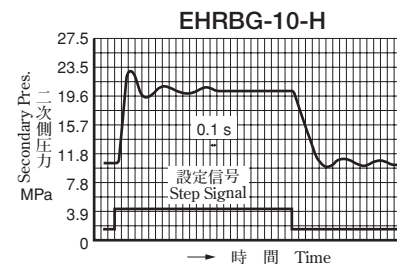
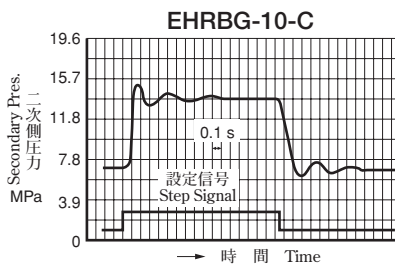
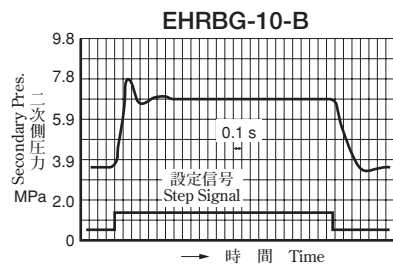
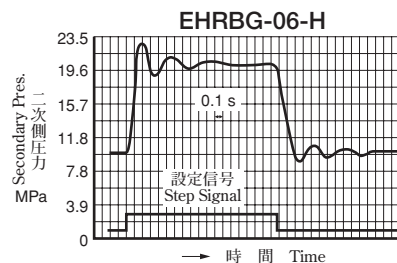
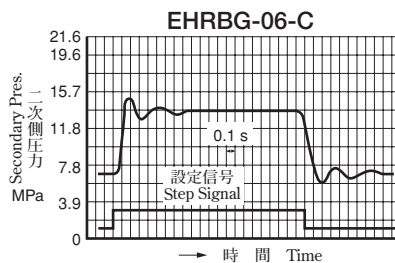
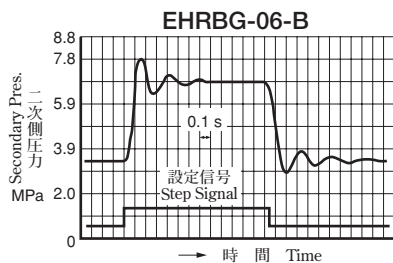

■周波数特性 Frequency Response

一次側圧力 Primary Pressure : 24.5 MPa
 負荷容量 Trapped Oil Volume : 20 L
 粘度 Viscosity : 30 mm²/s

